

Reducing Our Impacts

The Carbon Economy



CARBON HAS A VALUE!



In addition to being a measure of environmental impact, carbon has also become an economic measure.

Until now, emitting carbon (CO₂e) has been free. The cost of emitting carbon has been what economists call an 'externality' – something not factored into the price of goods and services.

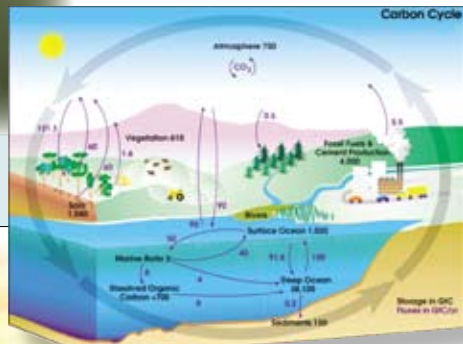
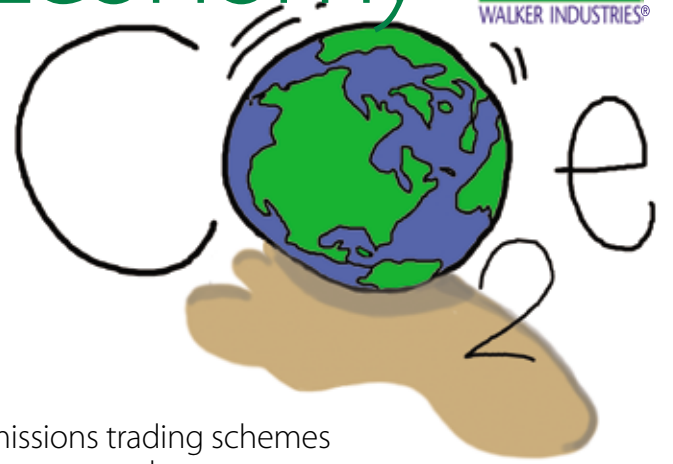

Through emissions trading schemes or government tax, carbon now has a value.

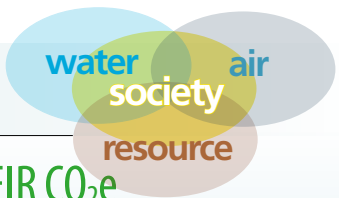

FOR THOSE THAT REDUCE THEIR CO₂e EMISSIONS THERE IS AN OPPORTUNITY.

Reducing CO₂e below acceptable limits creates a commodity that can be sold.

FOR THOSE THAT HAVE EXCESSIVE CARBON EMISSIONS, CARBON IS A LIABILITY.

Those facilities will have to either invest in their operations to reduce their emissions to acceptable levels or purchase someone else's carbon reductions or "carbon credits". This is what is known as a 'cap and trade system'.

Under voluntary carbon trading programs the price of carbon currently fluctuates between \$2 and \$20 per tonne of CO₂e.

CARBON PRESENTS A NEW AND FUNDAMENTAL CHALLENGE TO BUSINESS.

SUDDENLY, WE HAVE A COMMODITY THAT EVERY ORGANIZATION MUST ACCOUNT FOR. ▼

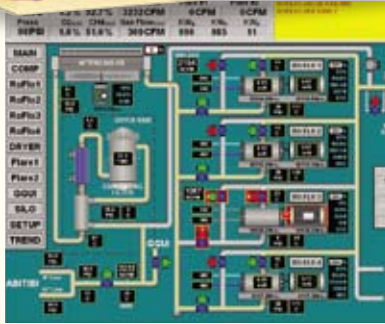

CO₂e PRODUCTION IS A COST AND A RISK. ▼

Companies with strong environmental values and practices stand to benefit from their diligence in the low carbon economy.

These companies are particularly well-positioned if they accurately measure their carbon footprint and actively manage their carbon impact to the environment.

QUESTIONS/DISCUSSIONS

1. By when is Walker aiming to have calculated our carbon footprint?
2. What CO₂e liabilities do you see at your operations?
3. What CO₂e assets do you see at your operations?
4. What steps do we need to take to become a low carbon company?

You must be the change you wish to see in the world.
Mahatma Gandhi

www.walkerind.com

Reduce Our Impacts
Our Environmental Messenger
 THE CARBON ECONOMY
 COMMIT ■ CREATE ■ PARTICIPATE